

SIEMENS

Ingenuity for life

Industrial machinery and heavy equipment

AMAZONE

Agricultural technology firm uses Simcenter, NX and Teamcenter to reduce time from concept to product

Products

Simcenter, NX, Teamcenter

Business challenges

Predict motion and strength behavior of complex agricultural machines

Improve performance and profitability

Reduce customer's cost and enable precision farming

Facilitate autonomous farming

Keys to success

Use customer-centric approach to product development

Create virtual test track using Simcenter and predict performance

Results

Reduced time from concept to product

Decreased number of prototypes

Reduced the amount of physical testing

Facilitated the prediction of design flaws earlier

Siemens PLM Software solutions enable AMAZONE to maintain its reputation for innovation and quality

Striving to produce more food

Here's a bit of food for thought. Right now the world population is around 7.5 billion people. By 2030, the United Nations predicts it will hit 8.5 billion. By 2050, this could reach 9.7 billion, of which 66 percent, or roughly 6.5 billion people, will live in cities.

This is a massive population burst in a relatively short time. One of the many questions is how are we going to manage this? Clearly, the additional food production needed to feed the world in 2050 will have to come from agricultural intensification. This translates into the need for better farming practices using more efficient and automated machines that can deliver more food. Agricultural equipment companies will be challenged to invent more innovative machines and systems that are adaptable to diverse agriculture markets,

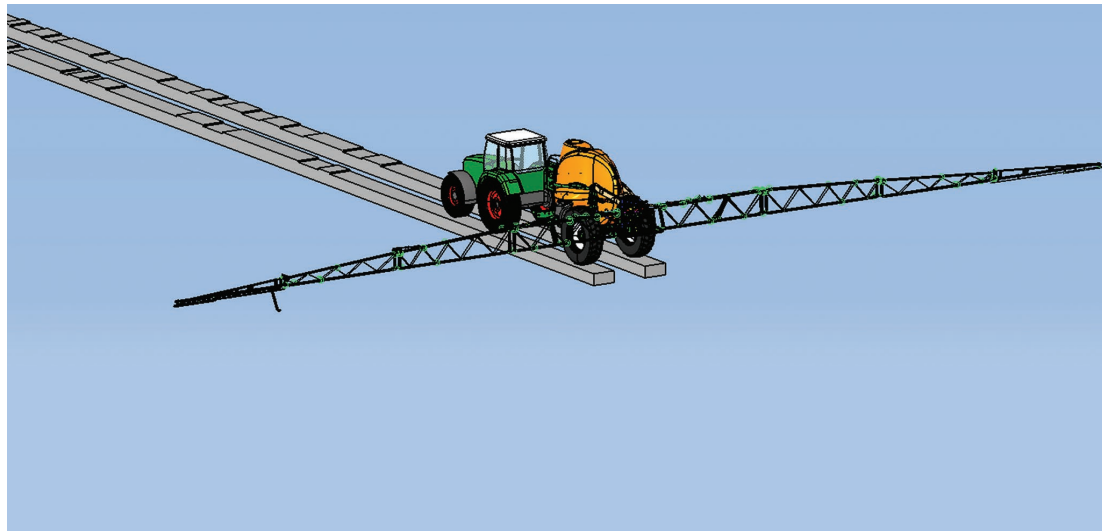

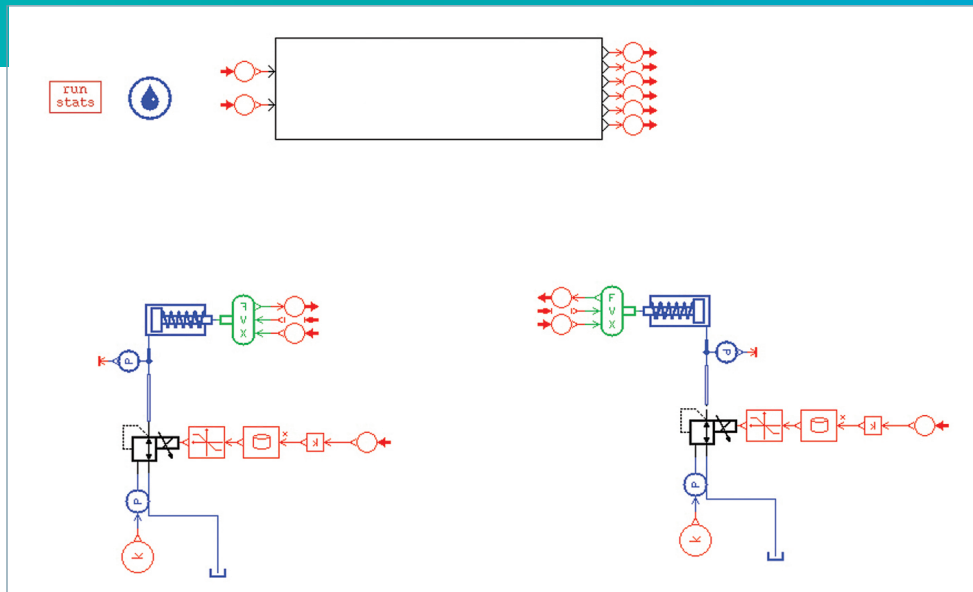

from the mega farms of Russia to the rural family farms in Bavaria, Germany.

This is where Anna-Gret Borchert, a calculation engineer in Hasbergen-Gaste, Germany, comes into the story. Borchert is responsible for computer-aided engineering (CAE) and design optimization at Amazonen-Werke H. Dreyer GmbH & Co. KG (AMAZONE), a fourth-generation, family-owned manufacturer of agricultural equipment. The company's product range is diverse, ranging from self-propelled crop protection sprayers, active and passive

cultivators and precision air seeders to landscaping and grounds-keeping equipment. AMAZONE offers a full-range of farming information technology (IT) packages that work with its equipment to improve efficiency and automation processes in the field.

Driving agricultural innovation

A pioneer in agricultural machines and automation, the firm is known for its vertically folding Super-S spray boom, which it introduced in 1994. The company was an early adopter of field automation,

“In 2013, I started using LMS Virtual.Lab and that was a revelation. I was able to model the whole machine, the test track, and all the motion behavior. It is just perfect.”

Anna-Gret Borchert
Calculation Engineer
AMAZONE

offering the first satellite-controlled fertilizer spreader via an on-board computer in 1995. One of the secrets to its success even back then was a customer-centric approach.

Thinking about how the product will be used daily is an important part of the AMAZONE culture. Will the spray boom be able to fit down a narrow farm alley or country lane? How accurate will it be in hilly fields? Does it drip when bouncing over public roads at high speeds?

Today Borchert and her colleagues continue to take a customer-centric approach to every product they work on. They are also championing new technology, like the simulation tools in the Simcenter™ portfolio, to help maintain AMAZONE's tradition of innovative, efficient and precise products.

"My main task is to simulate and optimize all types of products, but I mostly work on crop protection sprayers, like the Pantera 4502 self-propelled sprayer or the UX 11200 trailed sprayer," says Borchert. "My job is to study the motion behavior. With a price tag that starts around 100,000 euros and can go up past 300,000 euros, these big and complex machines are serious investments for our customers."

With such serious investments, AMAZONE knows their products have to deliver efficient and precise performance to compete in the market. Taking a customer-centric approach and creating interactive products that readily solve the issues at hand has always been part of the AMAZONE philosophy.

"You might actually say that some of our products are like a Porsche because you can really customize these machines," says Borchert. "That could apply to what type of radio you would like, what size and type of sprayer or seeder you need and if you want an active or passive suspension, to

what type of computer-controlled or active system is required. We try to consider every type of customer and make sure our products offer above-average performance and precision so they can benefit from their investment."

The secret is simulation

Like many other industrial manufacturers, the simulation and testing process has recently changed at AMAZONE. Just four years ago, it was common to have two or three product prototypes when designing a new agricultural machine. Today that has been reduced to one by improving the simulation process.

When designing a new product, AMAZONE CAE and computer-aided design (CAD) designers work iteratively to improve the design. The first steps take place in NX™ software, where the geometry is created. After the initial NX CAD work is completed, the CAE guides the design decisions. And that is where the Simcenter portfolio comes into play.

"We use the Simcenter product portfolio for coupled FEM, multi-body and hydraulics simulation," says Borchert. "For controls, we tend to use Simcenter Amesim™ or MATLAB, whichever works the best for the job."

The engineering team counts on Teamcenter® software as well to organize and control the product development and production workflow.

Make the mistakes in simulation, not in reality

The job of the CAE team, including Borchert, is to make sure the machines perform as they should, focusing on durability, efficiency and precision.

"Besides durability the main challenge is the motion behavior of the sprayer boom," explains Borchert. "If it is not set correctly, the crop spraying can be uneven. From an

"Because of the complexity of our machines, it is much easier to simulate with LMS Virtual.Lab Motion than MATLAB, a platform I used previously. It is not as detailed as in LMS Virtual.Lab Motion."

Anna-Gret Borchert
Calculation Engineer
AMAZONE

“In the past, it took us about one year from concept to production, and today we have cut that down to three or four months.”

Anna-Gret Borchert
Calculation Engineer
AMAZONE

engineering perspective, the motion of the sprayer boom is not rigid; it is a flexible motion. To simulate this, we had to combine the multi-body systems with the finite element method. We do this in LMS Virtual.Lab™ Motion, which is part of Simcenter, because it works really well.”

When Borchert analyzes the flexible body of the spray boom dynamically, she is looking specifically at vibrations and deflections. She models everything involved in the motion of the boom to create a virtual test track. This includes the tires, the tractor and everything else involved in the motion of the boom.

“When we simulate, our first aim isn’t necessarily to save time or money,” Borchert says. “This is what most people say, isn’t it? Our first aim was to see what is happening and discover the physics behind the design. We make all the errors in simulation and not in reality. This saves a lot of time and money.”

By adapting the new simulation process, Borchert discovered that working with prototypes has its disadvantages. Of course, with a real-life machine, engineers can examine it and take measurements, but they can’t see every detail.

“Solving this issue was our main goal when starting with multi-body simulation,” says Borchert. “Simulation lets you see what you want to see. You can look inside and measure what you think might be causing the issue in the model.

“Because of the complexity of our machines, it is much easier to simulate with LMS Virtual.Lab Motion than MATLAB, a platform I used previously. It is not as detailed as in LMS Virtual.Lab Motion. With LMS Virtual.Lab, I have all the joints exactly at the point where they are in reality. I can model the flexibility with FE models with millions of nodes. You have a more precise model and it is easier to model.”

Model validation and testing

Even though AMAZONE has shifted toward more simulation, testing remains an important part of the process. For Borchert, testing is a vital way to validate her models.

“We did some tests on the test bench to identify the motions and high frequencies,” says Borchert. “This is what we use for validation. Of course, we also do field tests on the test track. That is the main way we validate our models.”

“From an engineering perspective, the motion of the sprayer boom is not rigid; it is a flexible motion. To simulate this, we had to combine the multi-body systems with the finite element method. We do this in LMS Virtual.Lab Motion, which is part of Simcenter, because it works really well.”

Anna-Gret Borchert
Calculation Engineer
AMAZONE

Solutions/Services

Simcenter 3D
www.siemens.com/simcenter3d

NX
www.siemens.com/nx

Teamcenter
www.siemens.com/teamcenter

LMS Virtual.Lab Motion
www.siemens.com/plm/lms-virtual-lab/motion

Simcenter Amesim
www.siemens.com/plm/simcenter-amesim



Customer's primary business

Amazonen-Werke H. Dreyer GmbH & Co. KG (AMAZONE) develops and produces innovative agricultural technology with a high standard of quality, taking into consideration modern and economical arable farming systems. The company manufactures arable farming equipment in the sectors of soil tillage, sowing technology, fertilization and crop protection, and provides advisory, training and services.
www.amazone.net

Customer location

Hasbergen-Gaste
Germany

From concept to production in three months

"Now after four years we are saving time by reducing the prototypes to one," says Borchert. "This is the same for product development. In the past, it took us about one year from concept to production, and today we have cut that down to three or four months.

"For me personally, the jump to LMS Virtual.Lab was the biggest step in my career so far. While I was starting my PhD work in 2012, I only had MATLAB. In 2013, I started using LMS Virtual.Lab and that was a revelation. I was able to model the

whole machine, the test track, and all the motion behavior. It is just perfect."

Borchert and her colleagues will continue work on innovative and efficient Amazone products, like the recently launched SwingStop pro used in the UX 01 trailed sprayer. The product won the machine of the year award at Agritechnica for its unprecedented spraying accuracy and is just one example of how AMAZONE helps farmers all over the world by supplying tools with most precision possible, thus contributing to a more efficient and productive global food chain.

Siemens PLM Software

Americas +1 314 264 8499
Europe +44 (0) 1276 413200
Asia-Pacific +852 2230 3308

www.siemens.com/plm

© 2018 Siemens Product Lifecycle Management Software Inc. Siemens and the Siemens logo are registered trademarks of Siemens AG. Femap, HEEDS, Simcenter 3D and Teamcenter are trademarks or registered trademarks of Siemens Product Lifecycle Management Software Inc. or its subsidiaries in the United States and in other countries. Simcenter, Simcenter Amesim, LMS Samtech Samcef, LMS Samcef Caesam, LMS SCADAS, LMS SCADAS XS, LMS Smart, LMS Test. Xpress, LMS Soundbrush, LMS Sound Camera, LMS Test.Lab and LMS Virtual.Lab are trademarks or registered trademarks of Siemens Industry Software NV or any of its affiliates. STAR-CCM+ and STAR-CD are trademarks or registered trademarks of Siemens Industry Software Computational Dynamics Ltd. MATLAB is a trademark or registered trademark of The MathWorks Inc. All other trademarks, registered trademarks or service marks belong to their respective holders.

64325-A13 1/18 C