

Automotive

Talleres Cabré

Using digital simulation to meet intense competition

Product

NX

Business initiatives

New product development

Business challenges

Diversify to offer a wider range of springs

Provide customers with a faster response

Meet the highest quality standards

Keys to success

Integrated design and nonlinear analysis functionality

User-friendly software

High-quality drawings that improve communication with suppliers

Results

Ability to produce more new models without adverse effects

Improved quality and added value

Complex custom-made parts that comply with the strictest quality standards

Ability to compete on the European market

NX CAE and NX Nastran made it possible for this Spanish manufacturer to expand into custom-made leaf springs

Meeting business challenges head-on

More than 50 years ago Pablo Cabré started a small company dedicated to the repair of leaf springs. The company, called Talleres Cabré, moved on to manufacture its own springs and succeeded in surviving the disappearance of several other companies in the sector. Today, however, the 30- person company is in direct competition with major European manufacturers that supply leaf springs to the new vehicle

market. Through their distributors, these larger companies have invaded Talleres Cabré's market for leaf springs.

Talleres Cabré met this challenge head-on by completely overhauling its design and production systems, and by diversifying and extending the wide range of spring types it manufactures. The company accomplished this through the use of robust technological tools that have made product development faster and more flexible. With the implementation of these tools came the competitive edge the company needed – the ability to create custom parts meeting the strictest quality standards.



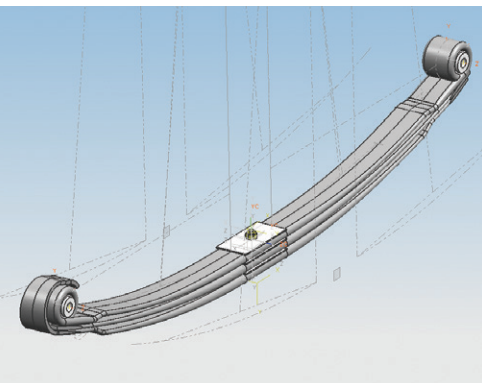
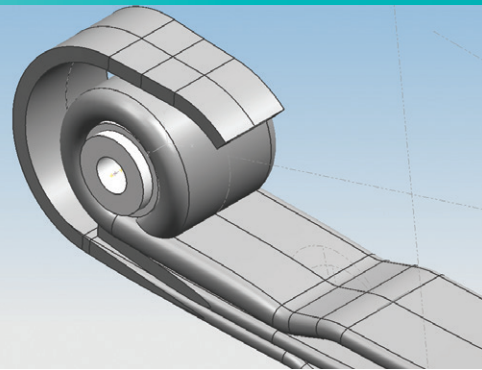

NX for rapid and quality design

Spain has a large number of commercial vehicles (one of the highest in Europe), and each model of vehicle contains a leaf spring whose size, weight and thickness may vary tremendously from one model to the next. This forces Talleres Cabré to constantly incorporate new spring models into production. Its previous design process was too slow to meet this demand, and also very rigid when it came to integrating changes into the designs. "We handle such a volume of parts that we cannot afford to waste much time implementing small changes," says Albert Cabré, manager of the Engineering Department at Talleres Cabré and grandson of the founder. "That's why we decided to look at other options."

For this small enterprise, it was essential to find a design solution that would "allow us to produce quality items in a flexible and fast way," says Cabré. With the goal of implementing a competitive strategy utilizing a state-of-the-art design/simulation solution, the company chose NX™ software and NX Nastran® software. Both NX and NX Nastran are products of Siemens PLM Software.

Explains Cabré, "We installed NX first and foremost to create accurate designs of the parts, to improve manufacturing and to

increase product quality. We also wanted to be able to design all new parts in house." The user-friendliness of NX has been one of its key advantages for Talleres Cabré. Due to the small size of the staff, only Cabré is able to dedicate himself, albeit sporadically, to designing parts. As he describes, "With NX CAE, designing new products is much faster and easier because we now have the ability to automate as much of our process as possible. And contrary to previous systems, even small changes are immediately carried forward to all the dimensions of the part. NX allows us to save a great deal of time because drawing ends up being a very quick operation, and making changes does not present problems."

Essential nonlinear calculations

Due to the characteristics of the leaf and the forces it needs to withstand, one of the fundamental aspects in designing a leaf spring is the calculation of nonlinear elements. For Talleres Cabré, this is one of the most beneficial aspects of the NX Nastran solution. "There are not many design solutions that incorporate nonlinear analysis," comments Cabré. "The advanced NX Nastran nonlinear package contains very powerful calculation instruments that help us produce our designs."

“With NX, design is much improved and simpler. The calculation of nonlinear elements is more efficient and does not fail as with other programs.”

Albert Cabré
Manager of the Engineering
Department
Talleres Cabré

Overall, as Cabré points out, "With NX, design is much improved and simpler, and the calculation of nonlinear elements is more efficient and does not fail as with other programs. I believe NX is considerably stronger." In addition, NX integrates various key processes in the same suite and facilitates the complete processing of springs. "NX has the benefit of having everything within the same environment," he adds. "We no longer require one program for design and another for analysis, with the inconvenience that this entails."

Even though spring leaves are very old components, their design presents a number of technical problems that are very difficult to evaluate, such as the friction between leaves. "At the moment, the technical literature shows that the design of finite elements is the subject of much research," explains Cabré. "CAE tools are applied broadly since, in addition to design, they allow you to see if the design that you initially produced really matches your needs. With more capacity for analysis, we can better comply with quality standards."

More rapid and flexible production

The NX CAE and NX Nastran combination has made Talleres Cabré more competitive. "It allows us to take yet another step in commercial terms, since we now have the necessary tools to handle the design of very complex, custom-made parts," Cabré

notes. The functionality inherent in NX CAE is what has enabled the company to expand its business into the production of custom springs. "Companies that require custom-made parts expect advice from the manufacturer since they do not have experience in matters of production," Cabré explains. "NX technology allows us to bring advanced tools and experience to the project, and ultimately to offer finished products with the best quality possible."

Since implementing NX CAE and NX Nastran, Talleres Cabré has experienced several other significant developments, not only with respect to drawing, but also with its ability to offer customers a more rapid and flexible service. "Our company is a service provider and when customers place their orders they expect a quick response on our part," says Cabré. "To turn out the product, it is essential that our operators have a clear idea of what they should do. The unified solution (NX, NX CAE and NX Nastran) allows us to create quality drawings, which improve and increase our production capacity."

NX also facilitates interactions with suppliers. Even when ordering raw materials from the Asian market, Talleres Cabré uses the functionality offered by NX. "It is very advantageous for us to present a clear idea of what we are looking for so that global suppliers can understand us," Cabré says.

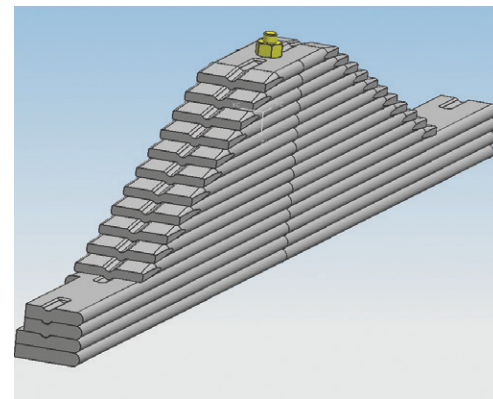
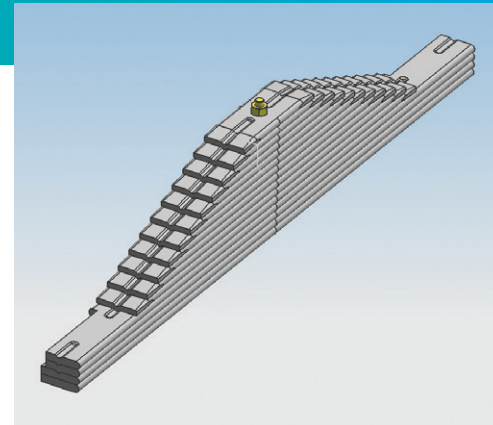

"NX technology allows us to bring advanced tools and experience to the project, and ultimately to offer finished products with the best quality possible."

Albert Cabré
Manager of the Engineering
Department
Talleres Cabré

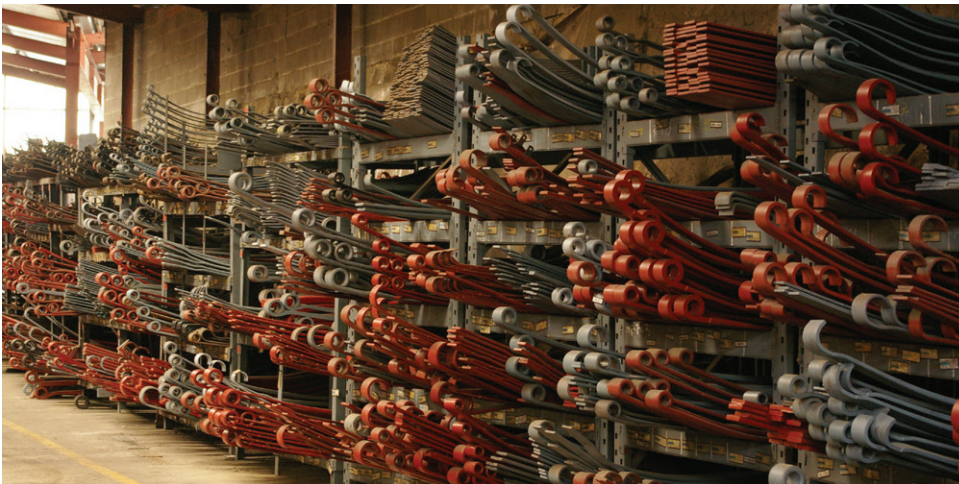

Solutions/Services

NX
www.siemens.com/nx

Customer's primary business

Talleres Cabré specializes in the production of leaf springs.
www.ballestascabre.com

Customer location

Lleida
Spain



At present, only the designs for new springs are entered into NX, although the company's plan is to incorporate existing models into the NX database as well. "We would like to use the software to create a complete catalogue of both old and new models," says Cabré. Another future plan is to hire a dedicated designer who will be in charge of custom parts.

Now that NX is in place, Cabré does not discard the possibility of competing directly in the mass production market.

"We have never tackled this market, but if we prepare ourselves for it, maybe we could do it at some time, and why not?" Cabré asks. Following the technological overhaul of Talleres Cabré, anything seems possible. "The major multinational companies have spared no efforts in marketing, but our technical quality is as good as theirs," he adds. "We are well established in Spain and now we should try and sell beyond our borders." No doubt NX will play a major part in ensuring that Talleres Cabré, led by the third generation, achieves all of its objectives.

"NX has the benefit of having everything within the same environment. We no longer require one program for design and another for analysis, with the inconvenience that this entails."

Albert Cabré
Manager of the Engineering
Department
Talleres Cabré

Siemens PLM Software

Americas +1 314 264 8499
Europe +44 (0) 1276 413200
Asia-Pacific +852 2230 3308

www.siemens.com/plm

© 2017 Siemens Product Lifecycle Management Software Inc. Siemens and the Siemens logo are registered trademarks of Siemens AG. D-Cubed, Femap, Fibersim, Geolus, GO PLM, I-deas, JT, NX, Parasolid, Solid Edge, Syncrofit, Teamcenter and Tecnomatix are trademarks or registered trademarks of Siemens Product Lifecycle Management Software Inc. or its subsidiaries in the United States and in other countries. Nastran is a registered trademark of the National Aeronautics and Space Administration. All other logos, trademarks, registered trademarks or service marks belong to their respective holders.

12081-A11 1/17 H